

Product Instructions

Bovine Total Milk Protein Rapid Kit

Lateral Flow Devices (LFD) for qualitative analysis of bovine total milk proteins

Product Description and Intended Use

The 3M™ Bovine Total Milk Protein Rapid Kit is intended for screening for the presence of bovine total milk proteins in clean-in-place (CIP) final rinse water, environmental swab samples, food ingredients and processed food products.

The 3M Bovine Total Milk Protein Rapid Kit utilizes a lateral flow device (LFD) that is an immunochromatographic test method utilizing a poly-clonal antibody which is specific for the detection of bovine milk proteins. Positive results are visualized by the presence of three lines; the test line, the hook line and the control line, when milk protein is present at or above 3 ppm for food raw ingredients, processed food products and CIP or rinse water solution, and at above 2.5 µg/mL per 100 cm² for surfaces. These limits may vary depending on the matrix. Samples containing more than 3% milk may result in an invalid test which will be noticed by the absence of the hook line and/or test line. The dynamic range of the 3M Bovine Total Milk Protein Rapid Kit has been shown to be 1.25 ppm and 1,500 ppm from bovine milk. The upper limit of detection has been shown to be approximately 1.5 mg/mL of NISTa 1549 in distilled water.

The 3M Bovine Total Milk Protein Rapid Kit is intended for use in the food and beverage industry by trained personnel. 3M has not documented the use of this product in industries other than food or beverage. For example, 3M has not documented this product for testing pharmaceutical, cosmetic, clinical or veterinary samples. The 3M Bovine Total Milk Protein Rapid Kit has not been evaluated with all possible food products, food processes and testing protocols.

The 3M Bovine Total Milk Protein Rapid Kit contains 25 tests, described in Table 1.

Table 1. Kit components

Item	Identification	Quantity	Storage
3M™ Bovine Total Milk Protein Lateral Flow Device (LFD)	Lateral flow device in a plastic cassette	25 devices individually packed.	Store at 2-8°C. Do not freeze.
3M™ Extraction Buffer	Bottle with Extraction Buffer	1 bottle containing 50 mL	Store at 2-8°C. Do not freeze.
Dilution Tubes	Microcentrifuge tube (2.2 mL volume capacity)	26 tubes	Store in a clean dry place.

Materials not provided in the kit:

- a. Swabs and pipettes.
- b. The use of vortex, timer and balance are recommended but not required for all samples.
- c. The use of a centrifuge is required for all chocolate and gum samples and it is recommended, but not required for all solid samples.

Safety

The user should read, understand, and follow all safety information in the instructions for the 3M Bovine Total Milk Rapid Kit. Retain the safety instructions for future reference.

⚠ WARNING: Indicates a hazardous situation, which, if not avoided, could result in death or serious injury and/or property damage.

NOTICE: Indicates a potentially hazardous situation, which, if not avoided, could result in property damage.

⚠ WARNING

To reduce the risks associated with inaccurate results:

- 3M has not documented the use of 3M Bovine Total Milk Protein Rapid Kit in industries other than food or beverage. For example, 3M has not documented this product for testing pharmaceutical, cosmetic, clinical or veterinary samples.



- 3M Bovine Total Milk Protein LFD should be read 11 ± 1 minutes after sample has been loaded on the lateral flow device.
- The 3M Extraction Buffer is designated for use with a specific lot of 3M Bovine Total Milk Protein LFD. Do NOT interchange 3M Bovine Total Milk Protein Rapid Kit components with other lots or kits.
- The 3M Extraction Buffer is designated for use with a specific lot of 3M Bovine Total Milk Protein LFD. Dispose of any remaining 3M Extraction Buffer once all 3M Bovine Total Milk Protein Lateral Flow Devices have been used.
- Store the 3M Bovine Total Milk Protein Rapid Kit as indicated on the package and in the product instructions.
- Always use the 3M Bovine Total Milk Protein Rapid Kit by the expiration date.
- Always use the 3M Bovine Total Milk Protein Rapid Kit at 20-25°C temperature.

To reduce the risks associated to false negative results:

- Use the 3M Bovine Total Milk Protein Rapid Kit for food and environmental samples that have been validated internally or by a third party.

To reduce the risks associated with exposure to chemicals:

- 3M Bovine Total Milk Protein Rapid Kit is intended for use in the food and beverage industries by trained personnel.

NOTICE**To reduce the risks of inaccurate results:**

- Refer to the Interpretation of Results section of the product instructions, to ensure accurate interpretation of the 3M Bovine Total Milk LFD.

Consult the Safety Data Sheet for additional information.

For information on documentation of product performance, visit our website at www.3M.com/foodsafety or contact your local 3M representative or distributor.

User Responsibility

Users are responsible for familiarizing themselves with product instructions and information. Visit our website at www.3M.com/foodsafety, or contact your local 3M representative or distributor for more information.

As with all test methods used for food analysis the test matrix can influence the results. When selecting a test method, it is important to recognize that external factors such as sampling methods, testing protocols, sample preparation, handling, and laboratory technique may influence results. The food sample itself may influence results.

It is the user's responsibility in selecting any test method or product to evaluate a sufficient number of samples to satisfy the user that the chosen test method meets the user's criteria.

It is also the user's responsibility to determine that any test methods and results meet its customers' and suppliers' requirements.

As with any test method, results obtained from use of any 3M Food Safety product do not constitute a guarantee of the quality of the matrices or processes tested.

Limitation of Warranties/Limited Remedy

EXCEPT AS EXPRESSLY STATED IN A LIMITED WARRANTY SECTION OF INDIVIDUAL PRODUCT PACKAGING, 3M DISCLAIMS ALL EXPRESS AND IMPLIED WARRANTIES, INCLUDING BUT NOT LIMITED TO, ANY WARRANTIES OF MERCHANTABILITY OR FITNESS FOR A PARTICULAR USE. If any 3M Food Safety Product is defective, 3M or its authorized distributor will, at its option, replace or refund the purchase price of the product. These are your exclusive remedies. You must promptly notify 3M within sixty days of discovery of any suspected defects in a product and return it to 3M. Please call Customer Service (1-800-328-1671 in the U.S.) or your official 3M Food Safety representative for a Returned Goods Authorization.

Limitation of 3M Liability

3M WILL NOT BE LIABLE FOR ANY LOSS OR DAMAGES, WHETHER DIRECT, INDIRECT, SPECIAL, INCIDENTAL OR CONSEQUENTIAL DAMAGES, INCLUDING BUT NOT LIMITED TO LOST PROFITS. In no event shall 3M's liability under any legal theory exceed the purchase price of the product alleged to be defective.

Storage and Disposal

Store all 3M Bovine Total Milk Protein Rapid Kit components at 2-8°C.

3M Bovine Total Milk Protein Rapid Kit components should not be frozen, exposed to UV light or exposed to prolonged heat (>30°C).

3M Bovine Total Milk Protein Rapid Kit components should not be used past the expiration date. Expiration date and lot number are noted on the outside label of the box.

Please note that each 3M Extraction Buffer lot is validated specifically for each LFD lot and is not interchangeable with any other lots or kits.

Dispose according to current local/regional/industry standards and regulations.

Instructions for Validated Methods

AOAC® Performance Tested MethodSM #091701



In AOAC Research Institute PTMSM studies, the 3M Bovine Total Milk Protein Rapid Kit was found to be a reliable robust method suitable for detecting bovine milk protein down to 3 ppm from multiple reference sources in food products and rinse materials, and 2.5 µg/mL per 100 cm² on surfaces.

- This method has been validated to detect milk in: soy milk, baked sugar cookies, chocolate dessert, CIP rinse water and 100 cm² samples from stainless steel surfaces.
- The dynamic range of the assay was determined to be between 1.25 ppm and 1,500 ppm for protein from bovine milk.

Instructions for Use

Follow all instructions carefully. Failure to do so may lead to inaccurate results. Ensure that all 3M Bovine Total Milk Protein Rapid Kit components are at ambient temperature (20-25°C) prior to use.

Sample analysis

1. CIP Final Rinse Water Samples

- 1.1 Label one microcentrifuge tube for each CIP sample.
- 1.2 Add 800 µL of 3M Extraction Buffer to a labeled microcentrifuge tube.
- 1.3 Add 200 µL of CIP final rinse water sample. Shake vigorously or vortex for 15 seconds to mix thoroughly to obtain an extracted sample.

Note: The pH of extracted sample should be between 5 and 10. Proceed to Troubleshooting section for additional information.

- 1.4 Remove one 3M Bovine Total Milk Protein LFD from package and place on a clean, dry, flat surface.
- 1.5 Transfer 100 µL of the extracted sample prepared in 1.3 using a clean pipette or pipette tip and apply it to the sample well on the 3M Bovine Total Milk Protein LFD. Start the timer for 11 ± 1 minutes. Proceed to Interpretation of Results section.

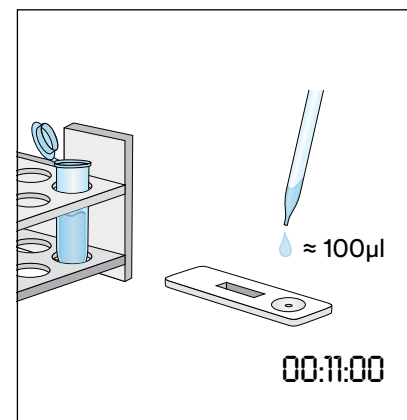
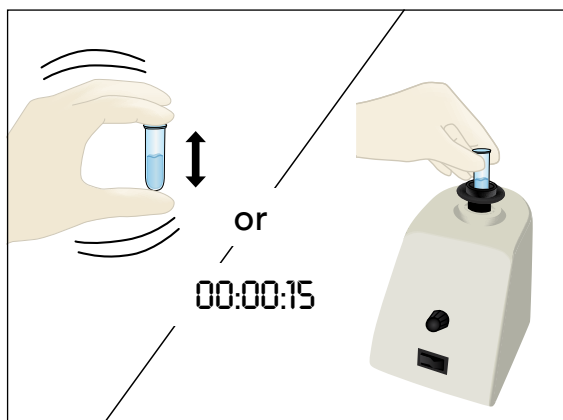
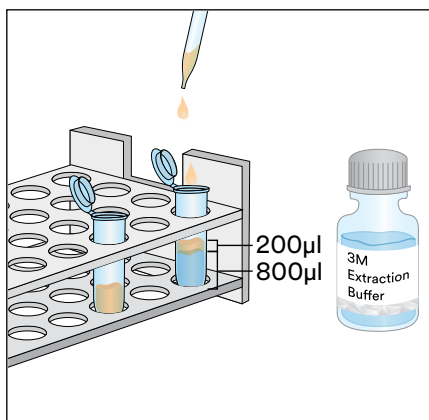

2. Environmental Swab Samples

- 2.1 Label one microcentrifuge tube for each Environmental Swab Sample.
- 2.2 Add 500 µL of 3M Extraction Buffer into a labeled microcentrifuge tube.
- 2.3 Take a clean swab and dip the entire tip into the microcentrifuge tube wetting the tip with 3M Extraction Buffer. Gently express excess liquid from tip by pressing swab tip lightly on the inside of the tube.

- 2.4 Take wetted swab and survey a 10 X 10 cm surface area maintaining the swab at a 30° angle with the surface. Rub the swab slowly and thoroughly over the surface area. Rub the swab three times over this surface, reversing direction between alternating strokes.
- 2.5 Take swab and insert it back into the pre-labeled tube and swirl swab several times to release any residues that might be on the surface of swab into the 3M Extraction Buffer. Break off swab tip in tube, cap tightly and mix well to obtain an extracted sample.
- 2.6 Remove one 3M Bovine Total Milk Protein LFD from the package and place on a clean, dry, flat surface.
- 2.7 Transfer 100 μ L of the extracted sample prepared in 2.5 using a clean pipette or pipette tip and apply it to the sample well on the 3M Bovine Total Milk Protein LFD. Start the timer for 11 \pm 1 minutes. Proceed to Interpretation of Results section.

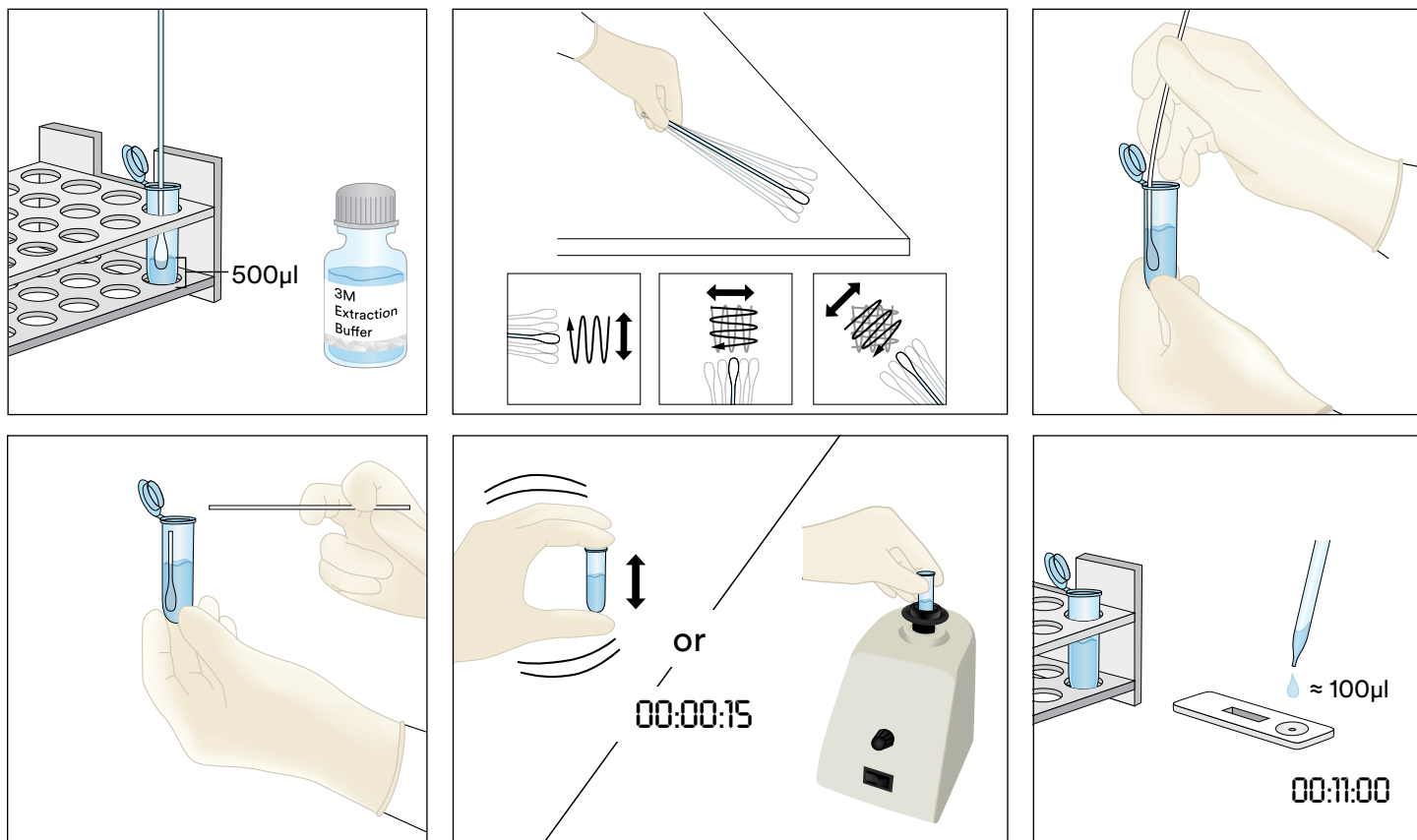

3. Liquid Samples Except Liquid Chocolate Samples

- 3.1 Label one microcentrifuge tube for each liquid sample.
- 3.2 Measure 900 μ L of 3M Extraction Buffer into a labeled microcentrifuge tube.
- 3.3 Add 100 μ L of a well-mixed sample. Shake vigorously or vortex for 15 seconds to mix thoroughly to obtain an extracted sample.

Note: The pH of extracted sample should be between 5 and 10. Proceed to Troubleshooting section for additional information.

- 3.4 Remove one 3M Bovine Total Milk Protein LFD from package and place on a clean, dry, flat surface.
- 3.5 Transfer 100 μ L of the extracted sample prepared in 3.3 from the middle (aqueous) layer using a clean pipette or pipette tip and apply it to the sample well on the 3M Bovine Total Milk Protein LFD. Start the timer for 11 \pm 1 minutes. Proceed to Interpretation of Results section.

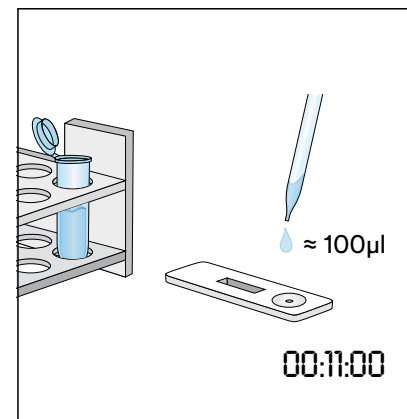
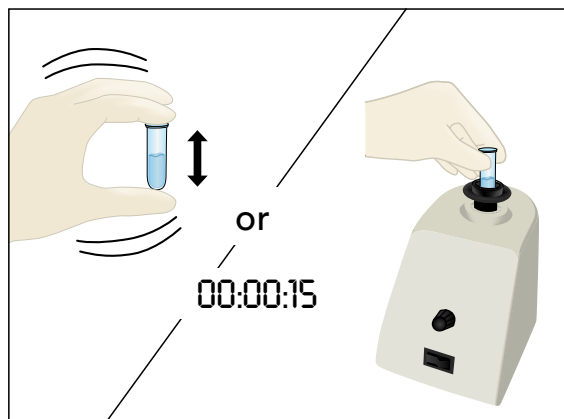
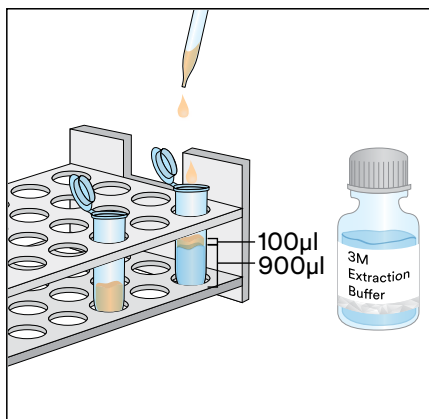

4. Liquid Chocolate Samples

- 4.1 Label two microcentrifuge tubes for each Liquid Chocolate Sample.
- 4.2 To make a prepared sample, add 500 µL of a well-mixed Liquid Chocolate Sample and add 500 µL of 3M Extraction Buffer into one labeled microcentrifuge tube and shake vigorously to mix thoroughly or vortex for approximately 15 seconds.
- 4.3 Add 900 µL of 3M Extraction Buffer into the second labeled microcentrifuge tube and add 100 µL of the Prepared Sample from step 4.2. Shake vigorously to mix thoroughly or vortex for approximately 15 seconds.
- 4.4 Centrifuge for 20-30 seconds at 5000-7000 rpm (3000 x g). The supernatant is the extracted sample.
- 4.5 Remove one 3M Bovine Total Milk Protein LFD from package and place on a clean, dry, flat surface.
- 4.6 Transfer 100 µL of the extracted sample prepared in 4.4 from the middle (aqueous) layer using a clean pipette or pipette tip and apply it to the sample well on the 3M Bovine Total Milk Protein LFD. Start the timer for 11 ± 1 minutes. Proceed to Interpretation of Results section.

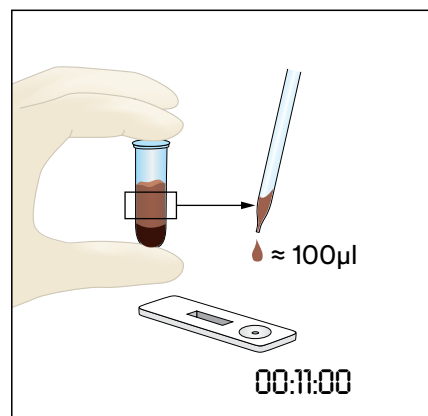
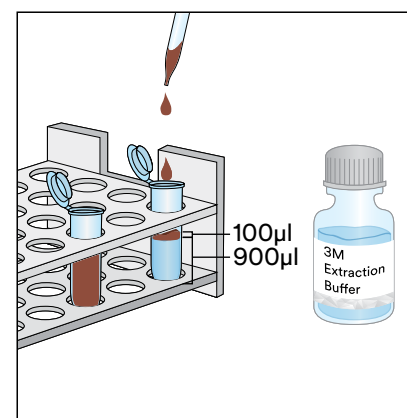
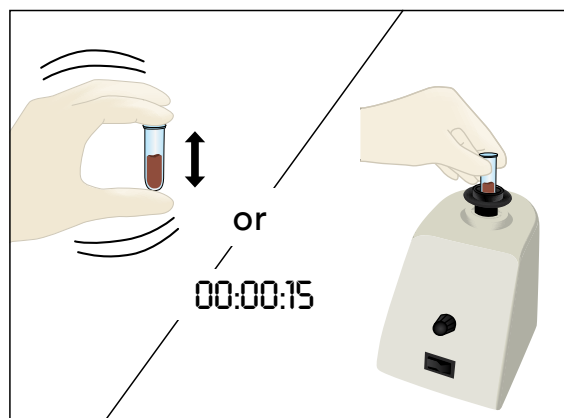
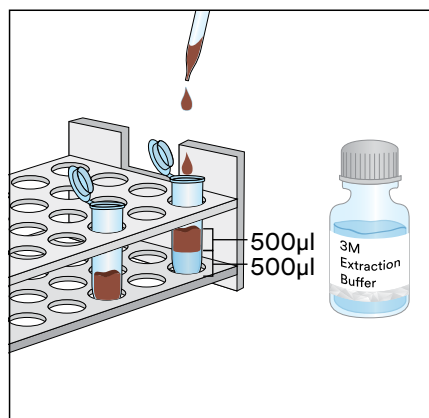

5. Solid Samples

- 5.1 Label one microcentrifuge tube for each non-liquid sample.
- 5.2 Grind sample into a fine homogeneous powder.
- 5.3 Measure 0.2 g of sample into a labeled microcentrifuge tube.
- 5.4 Add 1.8 mL of the 3M Extraction Buffer to the sample in the microcentrifuge tube. Shake vigorously or vortex for 15 seconds to mix thoroughly to obtain an extracted sample.

Note: Melt chocolate samples.

- 5.5 Centrifuge for 20-30 seconds at 5000-7000 rpm (3000 x g). The supernatant is the extracted sample.
- 5.6 Remove one 3M Bovine Total Milk Protein LFD from package and place on a clean, dry, flat surface.
- 5.7 Transfer 100 μ L of the extracted sample prepared in 5.5 from the middle (aqueous) layer using a clean pipette or pipette tip and apply it to the sample well on the 3M Bovine Total Milk Protein LFD. Start the timer for 11 ± 1 minutes. Proceed to Interpretation of Results section.

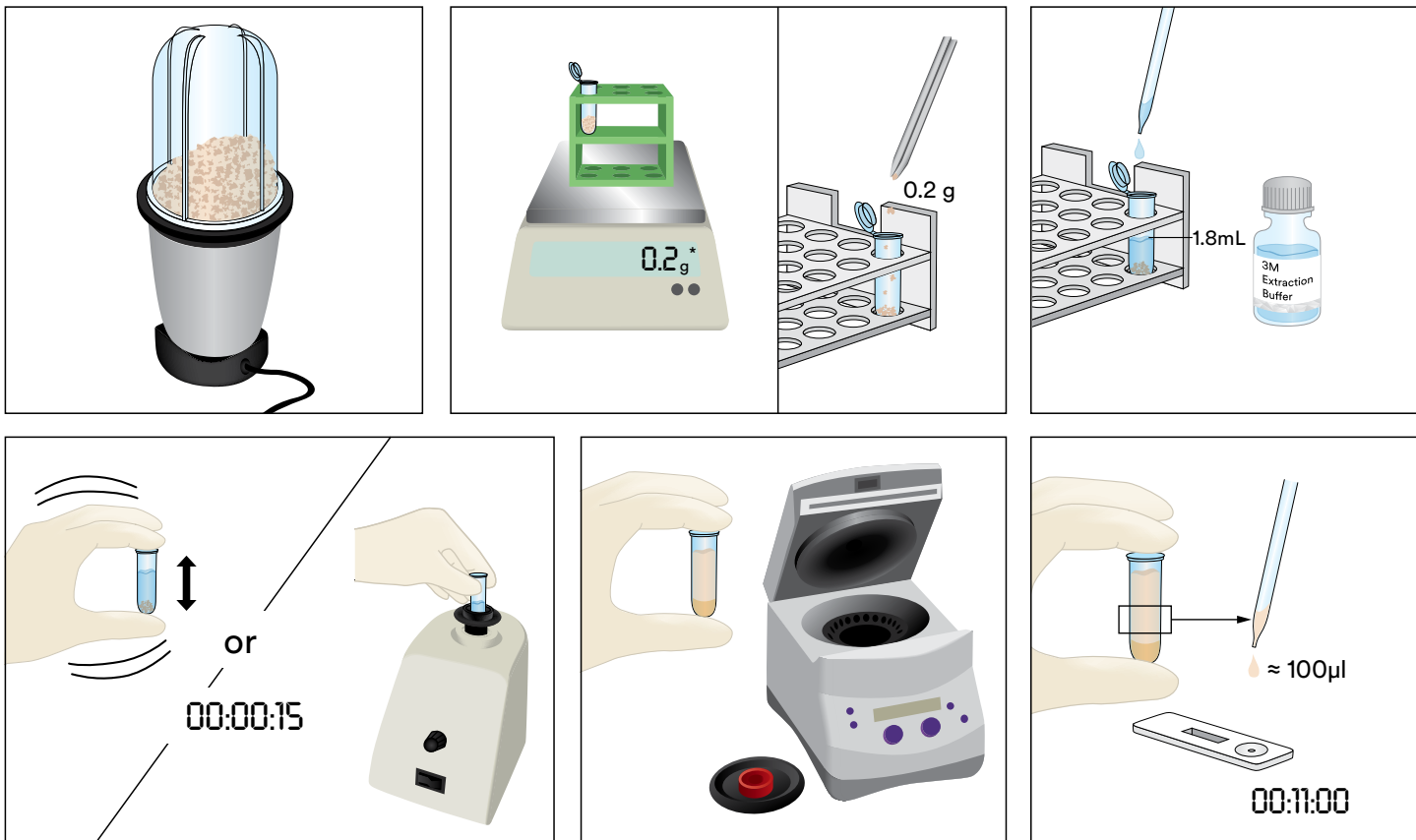

Interpretation of Results

The control line is next to the letter C on the 3M Bovine Total Milk Protein LFD. The test line is next to the letter T on the 3M Bovine Total Milk Protein LFD. The hook line is next to the letter H and/or in between the T and C lines. Note: Some LFD cassettes might not have an H marking on the side of the plastic cassette.

Read LFD at 11 ± 1 minutes after application of the sample. A sample is considered to be:

- a. Negative for bovine total milk protein when only the two lines furthest from the well; the control and the hook line, are visible on the 3M Bovine Total Milk Protein LFD.
- b. Positive for bovine total milk protein when all three lines (test, hook and control line) are visible on 3M Bovine Total Milk Protein LFD.
- c. Invalid, if the 3M Bovine Total Milk Protein LFD does not develop the middle hook line. The sample may be overloaded with bovine total milk protein and needs to be diluted.
- d. Invalid, if the 3M Bovine Total Milk Protein LFD does not develop the control line.

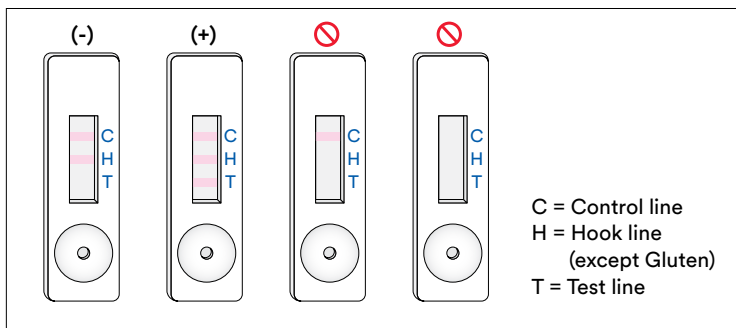

Any reading after 12 minutes from the initial application of the sample into the 3M Bovine Total Milk Protein LFD should be considered invalid. A reading at this time cannot be interpreted and can lead to erroneous results.

Troubleshooting

1. Sample fails to migrate across the strip within the first 5 minutes after application of the sample in the 3M Bovine Total Milk Protein LFD.

The sample may be too viscous and needs to be centrifuged if this was not already done during the preparation of the sample. If sample was already centrifuged, then preparing a 1:1 dilution with the 3M Extraction Buffer may be necessary. (Note: Detection limit may be higher depending on the dilution factor.)

2. A red dot appears on the test line but remainder of test line does not change color.
Sample particulate may have passed around the filter in the cassette, simply re-run the sample by taking a new 3M Bovine Total Milk Protein LFD from the kit and repeat the test.
3. The pH of extracted sample should be between 5 and 10. If pH is outside this range, further dilution may be required (i.e., prepare a 1:1 dilution with 100 μ L of the extracted sample and 100 μ L of 3M Extraction Buffer. Detection limit may be higher depending on the dilution factor.)

If you have questions about specific applications or procedures, please contact your 3M Food Safety representative or distributor.

Minimum Performance Characteristics

Lowest Limit of Detection ^(a)	3 ppm
Upper Limit of Detection	1.5 mg/mL

^(a) The lowest limit of detection is defined as the lowest concentration of the allergen in a test sample that can be distinguished from a true blank sample at a specified probability level¹.

References

1. Abbott, M., Hayward, S., Ross, W., Godefroy, S.B., Ulberth, F., Van Hengel, A. J., Roberts, J., Akiyama, H., Popping, B., Yeung, J.M., Wehling, P., Taylor, S., Poms, R.E., and Delahaut, P. (2010). Appendix M: Validation Procedures for Quantitative Food Allergen ELISA Methods: Community Guidance and Best Practices. *J. AOAC Int.* 93, 442-450.

Explanation of Symbols

www.3M.com/foodsafety/symbols

3M Food Safety

3M United States

3M Center
Bldg. 275-5W-05
St. Paul, MN 55144-1000
USA
1-800-328-6553

3M Canada

Post Office Box 5757
London, Ontario N6A 4T1
Canada
1-800-563-2921

3M Latin America

3M Center
Bldg. 275-5W-05
St. Paul, MN 55144-1000
USA
1-954-340-8263

3M Europe and MEA

3M Deutschland GmbH
Carl-Schurz-Strasse 1
D41453 Neuss/Germany
+49-2131-14-3000

3M United Kingdom PLC

Morley Street,
Loughborough
Leicestershire
LE11 1EP
United Kingdom
+(44) 1509 611 611

3M Österreich GmbH

Euro Plaza
Gebäude J, A-1120 Wien
Kranichberggasse 4
Austria
+(43) 1 86 686-0

3M Asia Pacific

No 1, Yishun Avenue 7
Singapore, 768923
65-64508869

3M Japan

3M Health Care Limited
6-7-29, Kita-Shinagawa
Shinagawa-ku, Tokyo
141-8684 Japan
81-570-011-321

3M Australia

Bldg A, 1 Rivett Road
North Ryde, NSW 2113
Australia
61 1300 363 878



3M Food Safety

3M Australia Pty Ltd
Bldg A, 1 Rivett Road
North Ryde NSW 2113

Phone 136 136
Web www.3M.com.au/foodsafety

3M New Zealand Limited
94 Apollo Drive
Rosedale Auckland 0632

Phone 0800 808 182
Web www.3M.co.nz/foodsafety

© 2018, 3M. All rights reserved.
3M is a trademark of 3M. Used under license in
Australia and New Zealand.

34-8721-9185-2