



DISPOSABLE PRODUCTS FOR CONTAMINATION CONTROL





pharmaclean



clean





Non animal clean

# PHARMACLEAN® IS THE NEW AM INSTRUMENTS® LINE OF PRODUCTS FOR CONTAMINATION CONTROL IN CLEANROOM ENVIRONMENTS

Products specifically designed to meet customer needs concerning effectiveness, safety, and compliance with regulatory requirements.

Pharmaclean is the result of the experience gained by AM Instruments over more than 25 years, that enables it to consistently conceive products that adequately respond to the increasingly strict quality and safety requirements required by life science.

## GMP ORIENTED

In line with GMP guidelines, our quality system is constantly evolving to ensure that all activities are carried out and managed to the highest quality standards, guaranteeing our customers' total adherence to regulatory requirements. Our quality department, coordinated by a certified GMP auditor, manages operations making our GMP-orientation a tangible reality.

This approach applies not only to our offer of products and services but to all AM Instruments' areas of activity, through the optimisation of processes, from R&D to production, from

customer service to internal logistics, and to technical assistance.

The AM team benefits from an ongoing GMP training program, geared to bridging the distance between customers and suppliers, and creating a synergy of operational procedures, objectives, and results.







# CUSTOM MADE TO GMP

## PHARMACLEAN PRODUCES CUSTOMISED SOLUTIONS ACCORDING TO CUSTOMER NEEDS

Pharmaclean responds to the specific needs of the life science industry, producing customised protection, packaging and sterilisation systems. Each customer request is discussed with the support of our QA, defining the operational flows and any verification and release test to offer a GMP compliant service and according to the specific requests of the customers.

You can request samples and quotes using the interactive form available on:  
[www.biotrading.com](http://www.biotrading.com)

The module allows the customer to provide all useful information to Pharmaclean operators in order to offer a rapid and effective response to sample production and quotation of the product.



# A GMP PRODUCTION FACILITY

ISO 9001:2015 CERTIFIED

## QUALITY CONTROL

Each phase of the process, from the raw materials acceptance to the release of the product, is rigorously controlled. We conduct environmental and microbiological monitoring in all manufacturing areas.

## ON-SITE AUDIT

During audits, our customers can check compliance with our stringent quality specifications implemented in the production area as well as to all processes.

You can schedule an audit by sending a request to our quality department at [sales@biotrading.com](mailto:sales@biotrading.com)

## CERTIFICATES

Each lot is delivered along with certificate of conformity and irradiation certificate, where applicable.

pharmaclean 

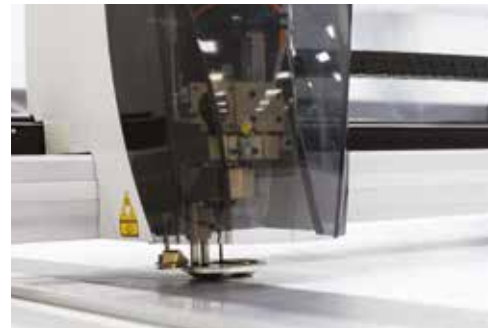

# PACKAGING, PROTECTION AND STERILISATION SYSTEMS



Pharmaclean products in DuPont™ Tyvek® material, for sterilisation and protection from dust, particles and microorganisms, are designed to offer total safety and resistance. They are customisable and easy to use. Unaffected by autoclave sterilisation processes.

All products come along with a certificate of conformity and a certificate of irradiation, where applicable. We maintain full documentation traceability, and can trace back all records and associated end users at any time.

## FEATURES AND BENEFITS

- completely in DuPont™ Tyvek® material
- custom shapes and sizes
- tear and perforation resistant
- easy to apply and remove
- low particles release
- excellent microbiological barrier
- uniform vapour penetration across the surface
- autoclavable
- sterile version available



DuPont™ and Tyvek® are trademarks or registered trademarks of E.I. du Pont de Nemours and Company.





## MINI-COVERS

---

### FOR GLASS CONTAINERS, BOTTLES, VALVES, PIPES AND INSTRUMENTATION

Pharmaclean Mini-Covers is a fast and safe system for the protection of glassware, vessels, valves, tubes and instrumentation (pressure sensor, etc.) during sterilisation processes. Latex-free elastic closing system, sewn with polyester yarn.

## LARGE-COVERS

---

### FOR THE STERILIZATION OF MACHINE PARTS, HOPPERS AND LARGE COMPONENTS

Pharmaclean Large-Covers are a safe and fast solution to wrap hoppers and individual parts of machines during the sterilisation process. Latex-free elastic closing system sewn with polyester yarn.



pharmaclean



## COVERS

---

### FOR TROLLEYS, TANKS, MACHINES AND EQUIPMENT

Pharmaclean covers provide an excellent solution to protect machines, carts and other equipment, of any shape and size, in production areas. Elastic, zip or drawstring closing systems.

## BAGS

---

### FOR COMPONENT STERILISATION

Pharmaclean bags are ideal for the packaging of tiny components, or large, bulky and uneven items. They ensure vapour delivery across the entire surface and quick drying. Drawstring or heat sealing closing systems.



## MITTENS

---

### FOR PROTECTION AGAINST CONTAMINATION RELEASED BY HEAT-RESISTANT AND INDUSTRIAL GLOVES USED IN CRITICAL APPLICATIONS

Low particulate release, autoclavable, antistatic, breathable and resistant to moisture and perforations. Customisable shape and size.



## NEEDLE & CLAMP COVERS

FOR USE IN FILLING MACHINES,  
RABS AND ISOLATORS

Custom shapes and sizes. Autoclavable.



## PALLET COVERS

IDEAL FOR THE PROTECTION OF PALLET SURFACES  
PRIOR TO THE INTRODUCTION INTO CONTROLLED AREAS

Designed to avoid direct contact between the load and the pallet surface. Available in Euro pallet or custom sizes.



## STERILISATION SYSTEMS

DEAL FOR STERILISING COMPONENTS AND  
TOOLS IN STERILE PRODUCTION AREAS

Bags and rolls in DuPont™ Tyvek® 1073B-PET-O/HDPE. The transparent side allows viewing the content. Closure by heat sealing. They are breathable and resistant to perforation warranting low particle release. Integral steam sterilisation indicator.



pharmaclean 

pharmacean





## PHARMACLEAN® PP AUTOCLAVABLE BAGS

The polypropylene bags are used for autoclaving waste contaminated by pathogens such as Petri dishes, flasks, tubes and other products related to the biological material cultures and their handling. Available in four standard sizes with 50 micron thickness, neutral, with sealed bottom edge. On request, customisable sizes, colours and labelling.

## ROUND BOTTOM LINER

LDPE or HDPE Pharmaclean cleanroom bags apply to round containers such as drums and buckets. The circular sealing on the bottom allows the bag to adapt to the tank without wrinkling. Ideal for transporting and storing liquids and solids, such as powders and granules, the bags are available with or without anti-slip additives and antistatic agents and are sterilisable by Gamma irradiation. Different sizes, colours and transparencies upon request. Compliant to EU 10/2011/EUPC/UPS and manufactured in an ISO 7 cleanroom.





# STERILE LDPE BAGS AND ROLLS

## FOR PRIMARY AND SECONDARY PACKAGING AND STERILITY MAINTENANCE

Handling of autoclaved items through lower class areas exposes sterilised products to contamination risks. Bags and rolls can also be used for packaging ends, avoiding direct contact between products and packaging materials, and for the effective collection and storing of samples.

Materials used to produce bags and rolls are cleanroom extruded and packaged, ensuring the levels of cleanliness required by the standards for contamination-controlled environments.



### FEATURES AND BENEFITS

- extruded, produced and packaged in a cleanroom
- for use in different contamination classes. Non-sterile version available
- available standards: rolls and bags; heat sealing or zip closure
- wide range of thicknesses and sizes
- moisture resistant
- easy sanitisation
- available also in hydrogen peroxide vapour-proof (VHP) packaging
- pharma grade LDPE bags available for primary packaging of pharmaceutical products

# BUCKET LINERS

## STERILE LINERS FOR MOP BUCKETS

A complete range of sterile bags for mop buckets: a quick and effective solution, in compliance with GMP requirements, that minimises cross-contamination risks while reducing cleaning cycle time and process costs.

### MAINTENANCE OF BUCKETS IMPLIES SANITISATION ISSUES

- cross-contamination risk if the bucket is not adequately cleaned and disinfected

### WHEN STERILISED IN AUTOCLAVE

- high process and labour costs
- long wrapping process
- risk of cross-contamination if not properly wrapped
- taken up space inside the autoclave

### FEATURES AND BENEFITS

- reduced bucket exposure to chemicals
- process cost reduction
- easier disposal of the sanitising solution
- buckets and carts can stay inside the sterile area and be used for the next cleaning cycle
- 100 microns thickness
- 100% LDPE
- suitable for 15 and 22-litre buckets (standard)
- custom sizes, thickness and packaging available on request



## A SIMPLE PROCEDURE AVOIDS CROSS-CONTAMINATION

Once the cleaning is complete, the bucket liner containing the contaminated solution is easily removed. Carts and buckets may stay inside the clean area, while the bucket liner will be carried out for disposal.

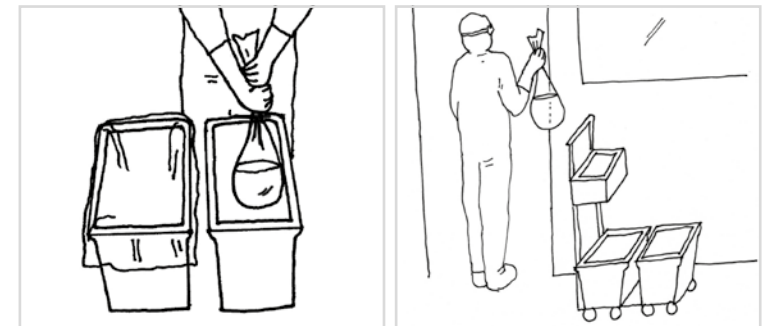

# REPACKAGING SERVICE FOR PHARMACEUTICAL APPLICATIONS

When the materials needed for pharmaceutical production are not adequately packaged, the pharmaceutical customer needs to provide for decontamination and repackaging to make them suitable for use in sterile environments and contamination controlled areas.

The Pharmaclean team can provide advice and complete management of the repackaging service operating in compliance with its Quality Management System

The Pharmaclean Quality Unit, in collaboration with the customer's team, analyses the need, develops a SOP according to the GMP, stipulates a Quality Agreement to standardise the process and guarantee the quality requirements. All with particular attention to costs and delivery times.

## OUR ADVANTAGES

- ISO 5 and ISO 7 Cleanroom
- GMP compliance
- risk assessment
- decontamination of materials achieved with specific products for use in cleanrooms
- finished product in single, double, triple pack, sterile or non-sterile according to the requests
- materials can be packed into Getinge La Calhène Beta bags
- custom sterile VHP packaging of tools (scissors, clamps, pens, filters, etc.) for use into isolators, RABS, pass-boxes
- sterilisation of materials by irradiation performed by qualified suppliers supported by process validation according to ISO 11137 and 11737 if required. Execution of the sterility test according to EU Ph 2.6.1
- identification and traceability of the whole process
- customised lot identification per customer's ERP/MRP systems
- service performed by highly qualified and continuously trained personnel
- customer's total outsourcing of the repackaging process with the consequent capacity of focusing on core activities





# WIPES

## MYWIPE® POLYCELL

Manufactured from a hydroentangled, nonwoven blend of polyester/cellulose. The fabric combines the absorbent properties of a natural fibre with the cleanliness and strength of a synthetic thread. With its low particle counts and solvent compatibility, MyWipe is ideal for general cleanroom wiping, spill control and precision device cleaning. No chemical binders.

- double bag cleanroom packaged
- autoclavable
- Gamma irradiated version available
- basis weight: 65 g/m<sup>2</sup>

### AVAILABLE DIMENSIONS

- 9" x 9" (23 x 23 cm)
- 12" x 12" (30 x 30 cm)
- 18" x 18" (46 x 46 cm)

## MYWIPE® POLY

Constructed from 100% continuous-filament polyester. Ideal for very critical environments due to the extremely low fibre and particle release and absorption capacity. Ultrasonic sealing. The wipe resists abrasion and is highly recommended for cleaning stainless steel, sensitive equipment, optical, magnetic and glass surfaces. No chemical binders.

- autoclavable
- cleanroom laundered and double bagged
- Gamma irradiated version available
- basis weight: 132 g/m<sup>2</sup>

### AVAILABLE DIMENSIONS

- 9" x 9" (23 x 23 cm)





## MYWIPE® TWO-PLY POLY

Constructed from 100% double layer continuous-filament polyester with sealed edges. Ideal for very critical environments and class ISO 4 and 5 cleanrooms. The ultrasonic sealing ensures extremely low fibres and particles release. Also available with laser sealed edges, this wipe is highly recommended for use in semiconductors and microelectronics.

- resistant to abrasion
- high absorption capacity thanks to the double layer
- autoclavable
- cleanroom laundered and double bagged
- Gamma irradiated version available
- basic weight: 225±5 g/m<sup>2</sup>

### AVAILABLE DIMENSIONS

- 12" x 12" (30 x 30 cm) - ultrasonic sealing
- 18" x 18" (46 x 46 cm) - laser sealing



## STERILE MYWIPE® POLY

Constructed from 100% continuous-filament polyester. Ideal for very critical environments due to the extremely low fibre and particle release and absorption capacity. Ultrasonic sealing. The wipe resists to abrasion and is highly recommended for cleaning machinery, sensitive equipment, glass and stainless steel surfaces. No chemical binders. Each package shows a sterilisation indicator, product code and lot number and is delivered along with a certificate of irradiation and conformity.

- cleanroom laundered and double bagged
- sterilised by Gamma irradiation
- available in packs of 10 or 25 pieces

### AVAILABLE DIMENSIONS

Wide heat seal (5 mm)

- 12" x 12" (31 x 31 cm)
- basis weight: 132 g/m<sup>2</sup>

Laser sealed edges

- 9" x 9" (23 x 23 cm)
- basic weight: 150 ± 5 g/m<sup>2</sup>

pharmaclean 

## MOP COVERS



### DISPOSABLE MONOLAYER MOP OVER-COVER

Polyester/cellulose single-layer mop cover; particularly suited to protect reusable covers. Each piece is individually double bagged.

### DISPOSABLE FLAT MOP COVER

Available in two variants:

- padded polyester/cellulose: the fabric combines the absorbent properties of a natural fibre with the low linting and strength of a synthetic thread
- padded 100% polyester: the fabric guarantees low particle release, and a high degree of absorption

Each piece is individually double bagged. Suitable for Bi-Mop and flat mop heads (400 x 100 mm).

All covers available in the Gamma irradiated sterile version.





## POLYESTER MOP COVER

100% polyester disposable mop cover with elastic, packed in a cleanroom and autoclavable. Developed for applications that require high absorption capacity and low particle release. Extremely easy to fit and replace during use.

Available sizes:

- 180 x 100 mm, particularly suitable for cleaning isolators
- 400 x 200 mm, particularly suitable for cleaning walls, ceilings and floors
- 60 x 400 mm, with closing laces, ideal for cleaning grids, areas surrounding process machines and difficult to reach areas



## ISOLATOR TOOL COVER

Disposable 100% polyester double layer cover with elastic, produced and packaged in a cleanroom. Developed for isolator cleaning tools. They are easy to fit and replace during cleaning operations.

All covers available in the Gamma irradiated sterile version.

# CLEANING TOOLS

---

A COMPLETE LINE OF ACCESSORIES TO MEET THE SPECIFIC REQUIREMENTS OF PHARMACEUTICAL PRODUCTION STERILE ENVIRONMENTS

ALL CLEANING TOOLS ARE AUTOCLAVABLE AND FULLY MEET THE STANDARDS SPECIFICATIONS AS OF CONSTRUCTION, MATERIAL COMPATIBILITY, DECONTAMINATION AND RESISTANCE TO BIOCIDES.

## MOOPY&CLEANUS®

---

Entirely made of mirror finished stainless steel. The handle can be disassembled into two parts to facilitate autoclave sterilisation. The Cleanus sponge can be easily removed and is completely autoclavable.



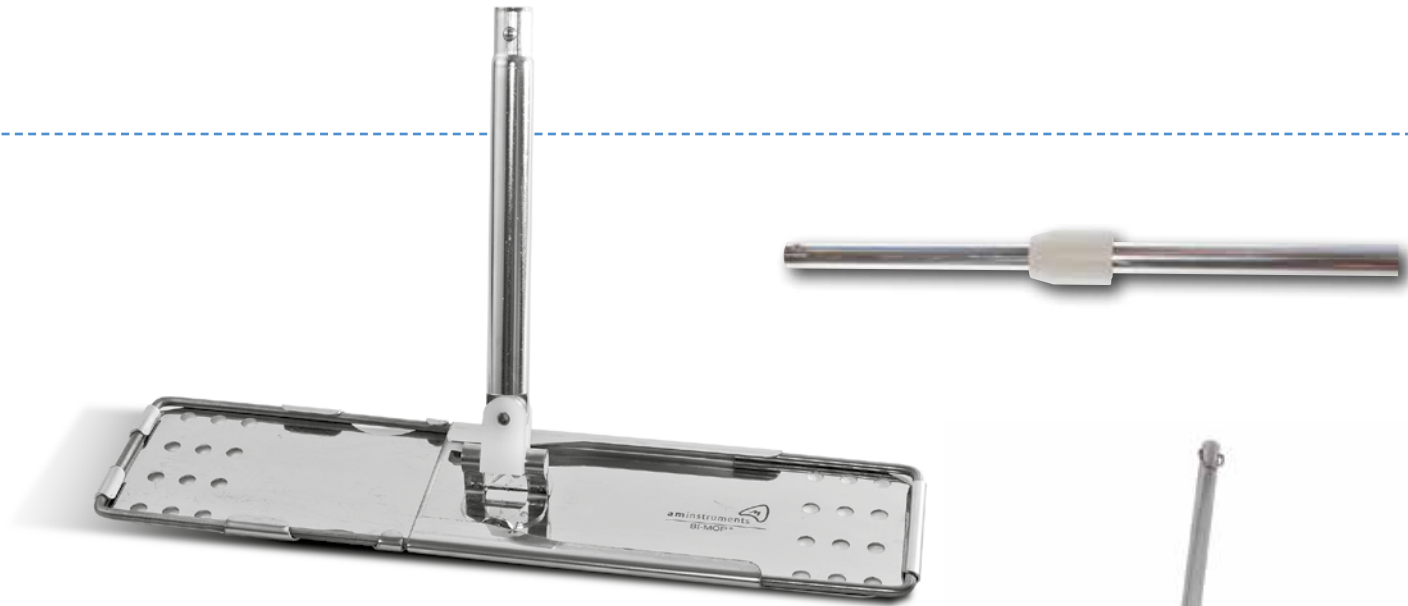

## BI-MOP®

Flat mop head made of electropolished AISI 304 stainless steel with PVDF joint. Suitable for cleaning floors, walls and ceilings. Completely autoclavable. Head size 387 x 100 mm. The head is available for use with a standard handle (1200 mm), a divisible handle (600 + 600 mm) and a lightweight extendible handle (1100 - 2100 mm).

## WIPE&GO

Flat mop head made of electropolished AISI 304 stainless steel with PVDF joint. Suitable for cleaning floors, walls and ceilings. Head size: 400 x 120 mm. The use of suitable size wipes (400 x 250 mm minimum) is recommended; the wipes are secured to the mop head by AISI 302 stainless steel springs. Completely autoclavable.

A removable silicone pad, quoted separately, can be laid on the mop head, between the steel base and the wipes.





# ACCESSORIES

## WIPPY

Silicone blade for excess liquid removal with electropolished AISI 304 stainless steel handle. The handle and the blade can be separated to help introduction in the autoclave.

- total length 1500 mm
- handle length 1350 mm
- blade size 460 x 75 x 160 mm (l x w x h)
- Completely autoclavable.

## PICKUP

Electropolished stainless steel dustpan. The handle and the dustpan can be separated to help introduction in the autoclave.

- total length 840 mm
  - wall-hanging hook
- Completely autoclavable.

## WASTE BAG HOLDER

Bag holder completely made of AISI 304 stainless steel, mirror finishing.

- stainless steel tube structure for easy bag positioning
- 4 stainless steel clips to secure the bag
- 2 autoclavable castors (up to 130°C)
- 2 feet

Dimensions: 350 x 350 x 1090(h) mm.

# BUCKETS & WRINGER

---



Cleaning trolley for contamination controlled areas, comprised of an AISI 304 SS frame, Scotch Brite finish, 360° swivel casters and plastic buckets with stainless steel handles. Thanks to small size and swivel casters, the trolley is easily manoeuvrable, even in narrow areas. Both frame and buckets are autoclavable. Available with two or three plastic buckets, capacity 15 L, dimensions 46 x 15 x 24,5 cm (lwxhx).

## WRINGER

---

Perforated stainless steel flat wringer. Suitable for flat mop heads, maximum width 46 cm (18"). Fits on 15 L buckets.



# CLEANROOM STATIONERY

## ANTIBACTERIAL STERILE PEN



Pharmaclean sterile ballpoint pen made of patented bacteriostatic material. Permanent effect, resistant to abrasion and chemical decontamination. Extensive tests carried out by applying different types of microorganisms to the pen's surface, in compliance with ISO Standards 22196:2011, show a reduction of the initial bioburden by exceeding 99%. Fitted with a clip, this is a click ballpoint pen with retractable tip mechanism, with no cap, for improved handling when wearing sterile gloves and isolator gloves.

Pharmaclean pen is available with black and blue ink. The product is sterile by Gamma irradiation. Each box shows a sterilisation indicator, product code number, lot number, and expiration date, and is delivered along with a conformity and irradiation certificate

Available also in hydrogen peroxide vapour-proof (VHP) packaging.



## STERILE MARKER

Each box shows sterilisation indicator, product code number, lot number, and expiration date, and is delivered along with a conformity and irradiation certificate.

Available in the following variants:

- fast-drying fine tip
- medium tip, alcohol-resistant black
- medium tip, permanent blue or black ink
- medium tip, permanent blue or black ink, VHP resistant packaging



## PAPER

### CLEANROOM PAPER SATURATED WITH SYNTHETIC POLYMERS OR LATEX

- weight: 80 and 100 g/m<sup>2</sup>
- no organic fillers
- high heat resistance
- ideal for laser printers and photocopiers
- autoclavable
- A4, A3 size
- available in different colours

### A4 POLYESTER PAPER

- weight: 160 g/m<sup>2</sup>
- 122 microns thick
- compatible with laser printers and photocopiers
- resistant to perforation
- writable with pens and pencils
- water resistant
- autoclavable
- available in different colours



## LABELS

### LABELS FOR CLEANROOM USE

- available in A4 sheets, on tear-resistant film, with removable or permanent adhesive, writable and compatible with most printing techniques
- broad range of sizes
- autoclavable

## NOTEBOOKS

### CLEANROOM SPIRAL NOTEBOOK SIZE A4, A5, A6

- synthetic, translucent cover
- 100 writable pages, equal to 50 sheets
- weight 80 g/m<sup>2</sup>
- polymer-impregnated and coated paper
- no organic residues and latex-free
- A4 ruled version: white or blue
- A5/A6 ruled version: white only



## STICKY MATS

Multi-layer decontamination cleanroom mats with bactericide, for entry into contamination controlled areas.

The antibacterial additive is blended into the adhesive surface of the mat and remains active for an extended period, ensuring substantial reduction of cross contamination.

Numbered corners to avoid the simultaneous tearing of more than one layer.

Available colours: blue, white, grey.

Different sizes available.

pharmaclean 

# EQUIPMENT

## MYFOG®

### FOG GENERATOR FOR AIRFLOW VISUAL TESTING IN CLASSIFIED ENVIRONMENTS AND IN LAMINAR FLOW CABINETS

According to the ISO 14644-3 Annex B7 international standard, airflows in all classified environments of any ISO class should be visually verified periodically. A generator of traces that identifies the speed and direction of airflows is listed among the suggested methods in the Annex mentioned above. The test is carried out in the areas under examination by taking pictures of the airflows made visible by the fog during "at rest" conditions (with no personnel present and no production equipment in use). Moreover, MyFog is also used during simulations of critical production process activities. The purpose of this type of test is to verify and certify that the airflow, set up to protect critical areas, is working efficiently.

#### FEATURES AND BENEFITS

- visualisation of airflow directions in classified environments, laminar flow areas (i.e. liquid filling machines), weighing stations (e.g. powder weighing and sampling areas), laminar flow cabinets
- balancing pressures between rooms (visual indication)
- identification of air stagnation pockets
- personnel training
- works with WFI and PW only
- no residues of chemicals or oil
- cold mist generation (no warm-up required)
- remote control, with start and stop, mist speed and intensity adjustment
- CE marked



pharmaclean



## MYPAGE<sup>®</sup>+

### BROADCAST MESSAGING SYSTEM

MyPage+, specifically designed for the cleanroom environment, offers the possibility of displaying a variety of templates and a number of different messages at the same time. Messages can also be scheduled and a time limit can be set after which a message will disappear. There is no limit to the number of devices that can be installed inside a facility. They can be managed individually or in groups, assigning a specific ID to each of them, and allowing to deliver simultaneous messages in different areas of the plant.



#### FEATURES AND BENEFITS

- display of scheduled or instant messages
- display of NTP (network time protocol)
- display of one or more templates containing videos, images, texts
- display of emergency messages with priority over other content
- possibility to add content via web application with any electronic device logged on to the network
- application access via user name and password with different levels of authorisation
- possibility to manage MyPage+ as an individual device or in groups of devices
- possibility of connecting to the customer SCADA system to show values such as differential room pressure, temperature, humidity, particle counting and more

# HANDS DISINFECTION



## MY&CLEAN<sup>®</sup>+

### AUTOMATIC GLOVED HAND SANITISATION

My&Clean+ is a device that allows a safe, contamination-free gloved hand sanitisation by automatically releasing a liquid solution. A photocell detects the presence of the hand at a specific distance from the spraying nozzle, and an automated mechanism activates the bottle trigger delivering the solution. My&Clean+ is specifically developed for sterile cleanroom environments. Once the bottle is placed inside the device, the liquid solution is supplied according to the simple procedure described above, no tubes, no tanks, no cross contamination caused by bottle handling. Multiple devices can be installed monitored by the remote My&Clean+ Station.

#### BENEFITS

- no risk of cross contamination
- possibility to continue using the validated liquid solution
- possibility to incorporate the device in the company supervising system
- specifically developed for sterile cleanroom environments
- responding to GMP data recording
- repeatability
- traceability

Also available in the basic version.



## MY&CLEAN<sup>®</sup> + STATION

### CONTROL CONSOLE

My&Clean+ Station is the control console for managing all networked devices. The console allows to:

- record and manage operators
- setup the disinfection SOP's parameters: i.e. number of sprays, frequency and contact time
- check the solution quantity level
- review the data record set for each device
- verify the status of each device (i.e. alarms, solution expiration date, mechanical failures)
- generate reports

The station stores all data from each networked device and is accessible from a browser to query data and generate reports. The database includes all the occurred events along with the operator ID, starting from the most recent.

## CLEANJET®

### AUTOMATIC ATOMISER FOR GLOVE DISINFECTION

When placed in a locker room or in a production department, CleanJet guarantees a fast and safe glove disinfection and reduces glove consumption. An automatic proximity detector senses the presence of a gloved hand and releases an alcohol-based disinfectant solution.

CleanJet's tank has a maximum capacity of 700 ml. A double led indicates the minimum level and, while filling up, the maximum level. When the minimum level of liquid is reached, in addition to the visual alarm, an acoustic signal informs about the need of filling up.

### AUTOCLAVABLE HANDS-FREE DISPENSER

A wall-mounted dispenser in polished stainless steel designed for housing a 1-litre trigger bottle hand sanitiser. The solution is dispensed by acting on the lever.



# BIODECONTAMINATION

## STERISPRAY® SYSTEMS

Designed for decontamination of sterile pharmaceutical areas. Used with appropriate biocides, they guarantee fast fumigation and short contact time.

## STERISPRAY®

Connected to filtered compressed air (or nitrogen) via the 1/2" clamp.

- no electrical connections required
- the tank containing the liquid is placed inside the machine; a tube connects to the nebulising system
- front panel flow meter and pressure regulator to adjust flow
- dimensions: 250 x 230 x 508 mm (L x W x H).

## SMART STERISPRAY®

Atomiser for automatic pharmaceutical cleanroom biodecontamination.

Smart Sterispray is programmable through TCP/IP web interface protocol or TCP modbus to allow complete customisation, offering the possibility to treat large areas

The quantity of delivered biocide is adjustable using the web interface. Historical biodecontamination cycles data can be visualised and reports printed

- dimensions: 250 x 310 x 535 mm (L x W x H)



# MONITORING SYSTEMS ACCESSORIES

## STERISPRAY® MINI

- designed for small areas
- 6 mm tubing quick connection
- dimensions: 100 x 100 x 200 mm (L x W x H)



## SMARTPROBE®

### 1 CFM AUTOMATIC CLOSING ISOKINETIC PROBE

For controlling and automatically managing the opening and closing phases of the isokinetic particle sampling probe, avoiding the operator involvement inside the cleanroom. A pneumatic system opens and closes the device. Position sensors verify the status of the probe.

- dimensions: 132mm (H) x 64mm (L) - 2" 1/2 clamp connection
- material: AISI 316 L stainless steel
- flow rate: 1 CFM
- working pressure: 3/4 BAR
- maximum pressure: 6 BAR
- compressed gas: filtered oil-free compressed air or nitrogen
- power supply: 24 VDC





# TECHNICAL FURNITURE

With an AISI 304 Ni-Cr 18/10 stainless steel product line, AM Instruments offers a totally renewed work environment to operators in the pharmaceutical, chemical and cosmetic sectors. The ideal solution in every furnishing project.

## TECHNICAL SPECIFICATIONS

- corrosion resistant, it does not release harmful substances
- presents a compact non-porous surface
- shock absorbent and resistant to temperature changes
- high percentage of bacterial removal during cleaning cycles



The unique design and finishing of AM Instruments' chairs and stools, allow their introduction and use in sterile pharmaceutical production areas.

The five-leg base can be easily disconnected from the seat. This helps the cleaning of internal parts and introduction in small autoclaves.

## CHAIRS

### STAINLESS STEEL CHAIR WITH CASTORS STAINLESS STEEL CHAIR WITH GLIDES

AISI 304 SS chair, Scotch Brite finish. The chair can be decontaminated using disinfectant solutions and disassembled into two parts for autoclave sterilisation.

- ergonomic seat
- adjustable seat and back height
- seat height adjustable from 507 to 615 mm
- five-leg basis
- castors, antistatic castors or glides

## STOOLS

### STAINLESS STEEL STOOL WITH CASTORS STAINLESS STEEL STOOL WITH GLIDES

AISI 304 SS chair, Scotch Brite finish. The stool can be decontaminated using disinfectant solutions and disassembled in two parts autoclave sterilisation.

- adjustable seat height from 480 to 590 mm
- telescopic seat adjustment system
- five-leg basis
- castors, antistatic castors or glides



pharmaclean



# SUPPLY CHAIN

Our mission is the continuous improvement of resources and processes in the interest of our customers.

Purchasing, Customer Service and Logistics are coordinated and organised to be always compliant to the GMP requirements, implementing automated workflows and procedures, for the most effective allocation of activities.

The Supply Chain team works as one entity for the highest level of efficiency providing:

- complete information on products/services and related documentation
- error-free order processing and shipping
- order confirmation
- accurate, reliable and timely update against open orders
- on time/in full deliveries (thanks to our 2500 square meters of warehouse and internal logistics)
- compliance with Supply Agreements and Quality requirements

Call us at +31(0)297-286841 or write to:  
**sales@biotrading.com** for any information concerning your order.







# OFFICES IN ITALY AND SPAIN

AND A WORLDWIDE NETWORK

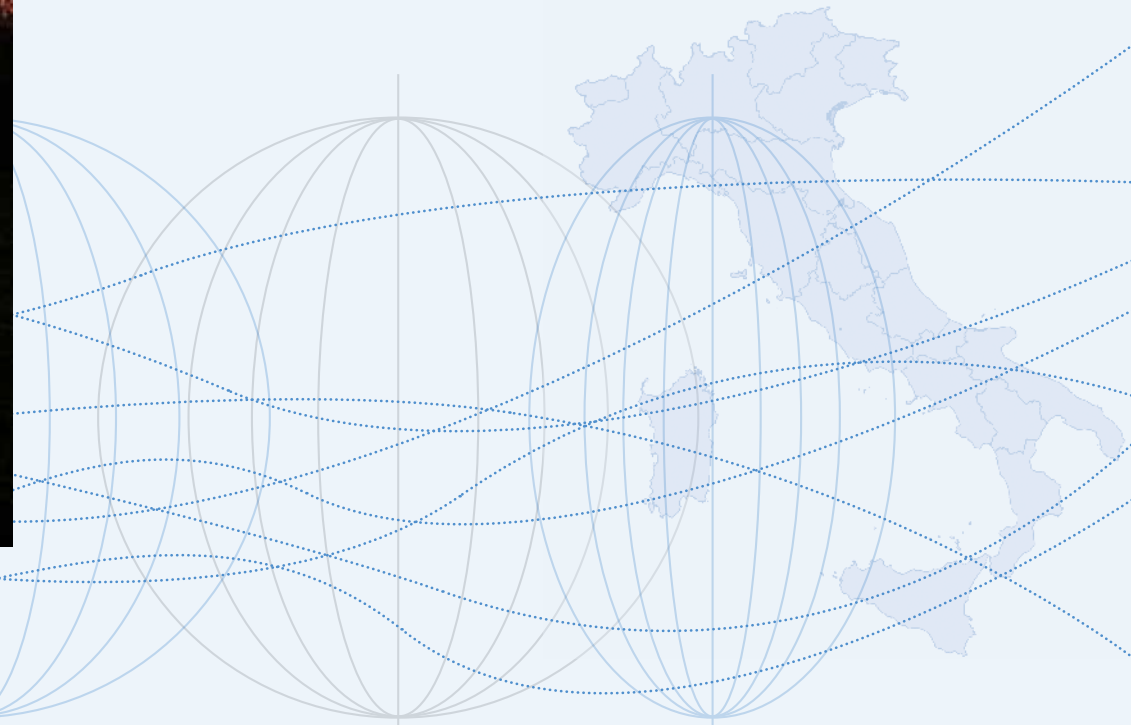



# ABOUT US

## AM INSTRUMENTS®

Since 1990 AM Instruments has been taking centre stage in the contamination control sector, paying particular attention to the quality requirements of the life science market.

The company is ISO 9001 certified since 2005 and started its GMP oriented program in 2015.

An R&D team dedicated to the development of innovative products responding to market needs. A remarkable commercial offer.

An organisation of 100 people with a common goal: serving customers with perceptible quality excellence. The best Made in Italy in contamination control.

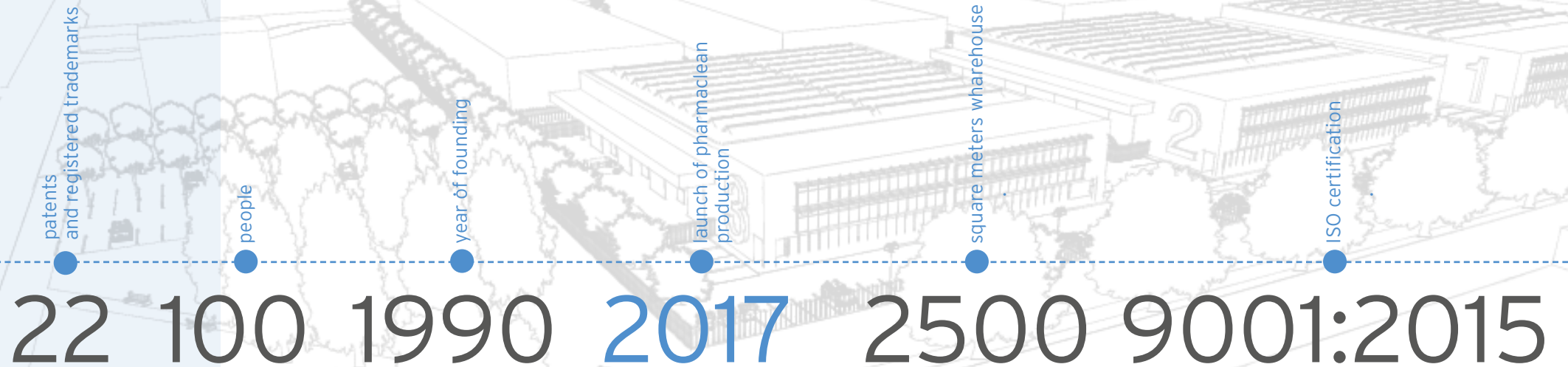



bioTRADING Benelux B.V.  
Communicatieweg 7  
3641 SG Mijdrecht  
The Netherlands  
Tel. +31(0)297-286848  
biotrading.com  
sales@biotrading.com

bioTRADING Belgium bvba  
Haachtsebaan 143  
3140 Keerbergen  
Belgium  
Tel. +32(0)155-00100  
biotrading.com  
info@biotrading.be

COMPANY WITH  
QUALITY SYSTEM  
CERTIFIED BY DNV GL  
= ISO 9001:2015 =

